

# Seismic simulation of seismically improved RE (rammed earth) buildings

Mohammad Hossein Hashemian\*<sup>1</sup> and Mahdi Vahdati<sup>2</sup>

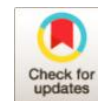

<sup>1</sup>Master of Architecture and Energy  
Tehran University, Tehran, Iran.

<sup>2</sup> Urban Development Department  
Shirvan Municipality, Iran

**\*Corresponding Author:**

✉ [Hashemian.mh@ut.ac.ir](mailto:Hashemian.mh@ut.ac.ir)

**Received:** 18 March, 2025

**Revised:** 25 June, 2025

**Accepted:** 12 July, 2025

**Published:** 31 July, 2025

## ABSTRACT

In this research, the seismic response of "Rammed Earth Structures" under an optimization, under the effect of acceleration maps of the Bam earthquake (which was the most destructive earthquake in Iran), was calculated using Abaqus 2021 simulation software. Since the structures in this earthquake were completely traditional this optimization has made for the seismic improvement of these types of structures. In such a way, cement and rebar materials were not used to improve tensile and compressive strength. However, a raft foundation was used in the dimensions of the building with a rigid and integrated connection, in addition to the material, which is based on gypsum and clay. The roofs in this design are presumed composite roofs with wooden beams, and their connection was also considered rigid. In this plan developed to study the effects of the dimensions of the foundation on the health of structures during the earthquake, three different depths were considered for the foundation. This caused the center of gravity of the structure to move towards the center of the foundation by increasing the dimensions and, as a result, the weight of the foundation, which reduced the stress during the earthquake load. Also, referring to Iran's 2800 regulations, the various seismic response components of these kinds of optimized structures were confirmed. Also, this seismic improvement has other advantages that make it unique such as the lowest price in construction, and industrial construction capability

**Keywords:** Rammed earth, structure, building, seismic improvement, Analysis, optimization.

## Introduction

Rammed earth buildings, or RE, are structures that are built with raw traditional materials. material (compacted soil) is an ideal choice. This material comes from natural soil sources and can be totally recycled after being compacted with many layers (unstabilized RE). In certain cases, a small amount of lime or cement (hydraulic binders) can be added to the mixture to enhance the mechanical resistance and durability (stabilized RE). Especially, RE material has low embedded energy and a positive hydrothermal behavior. However, the RE material has very low mechanical characteristics (compressive resistance from 1 MPa to 2.5 MPa) in comparison with the concrete material [1]. Furthermore, the tensile strength value of RE is very low (a ratio of ten compared to the compressive strength). Under extreme conditions such as earthquakes, knowing the tensile characteristic is necessary for structural design. Therefore, for RE houses built in seismic areas, the earthquake-bearing capacity of this type of structure is an important issue. A limit drift of 0.3% was proposed in [2], [3]. For the RE buildings to guarantee their resistance under seismic excitation. The study [4] showed that, for in-plane loading, a PGA of 0.223 g led to 0.238% drift and can be considered the maximum seismic excitation for the wall of a one-floor RE house. Considering out-of-plane loading, the results [5] showed that the resistance of the RE wall with an upper ring beam was decreased to 0.160 g (with a limit drift of 0.281%). However, the PGA and the limit drift mentioned above are validated only for one-floor RE houses and only for the same types of structures [4], [5]. To improve the earthquake-bearing capacity of the RE structures, different reinforcement techniques exist. Using a concrete or timber bond belt beam on the top walls can give a better balance to a RE building [6]. This reinforcement type prevents failures due to out-of-plane loading and decreases the local ruptures of the walls. The numerical study [7] analyzes the valuable effect of a strengthening solution that considers prestressed reinforcement using vertical steel.

The results showed that these reinforcements decreased the ductility and improved the bearing capacity of the RE walls. A study [8], a reinforcement system of strips of polyester fabric was used for RE walls. The bearing capacity was higher for reinforced walls than for unreinforced ones.

Used additive to maximize the compressive strength of the soil mixture is cement, sometimes combined with other additives (particularly fly ash). With high cement contents, around 10%, it is possible to obtain very high compressive strength, over 5MPa, meaning an improvement between 1.5 and 5 times the UCS of URE, even reaching a strength 10MPa in some cases [9].

As it happens with compressive strength, cement is the most common stabilizer added to RE to improve its elastic modulus. Studies regarding CSRE [10], [11], [12],

[13], [14] indicate elastic modulus within the range from 250 MPa to 750 MPa using cement contents between 2% and 10%. The same studies indicate that those values lead to an improvement of 150% to 500% with respect to URE specimens. Smaller improvements in the elastic modulus (40% to 140%) are obtained when using lime as a stabilizer [10], [15]. In various articles, various methods of strengthening them have been discussed, but the important point is that these researchers have generally considered only one aspect of this type of construction from various perspectives, such as price. The completion of the building with the proposed method, the duration of the construction, the feasibility of the design in the industrial dimension, and the beauty of the design have not been discussed, and basically, some studies on retrofitting or seismic improvement in them have not had a large impact on these types of buildings. Some of these innovations have been discussed further.

In the field of seismic improvement of these types of structures in 2019, a method was presented for reinforcing existing rammed-earth buildings by strengthening the walls with externally bonded fibers. Shaking table tests were conducted to study the seismic performance of two rammed-earth model structures—with and without reinforcement. They observed the crack patterns, failure modes, changes in dynamic properties, in-plane deformation, wall response, and roof-wall interaction in the models. The results confirm that the seismic resistance of rammed-earth structures reinforced using the proposed method was substantially improved [16].

Zou and colleagues, to improve the seismic performance of rammed earth buildings and retain the characteristics of local buildings, proposed a reinforcement measure with additional structural columns in that research. Three kinds of structural columns were designed: cast-in-place concrete, square steel tubes, and concrete-filled square steel tube core columns. Through the quasi-static experimental study on the rammed earth wall, the effects of different structural columns on the failure shape, bearing capacity, deformation capacity, and energy dissipation capacity of the wall were compared. The test results showed that adding structural columns on both sides of the wall could effectively restrain the rammed earth wall, restrain its brittle failure, significantly improve the energy dissipation capacity of the wall, and improve the seismic performance of the wall [17].

Zhou said in another article about the seismic survey of these types of structures that a series of proper structural measures for RE buildings were proposed to enhance their structural integrity. For acquiring/evaluating the seismic performance of those reinforced RE buildings, different typical structural styles were employed for constructing two 1/2-scaled, single-story buildings for shaking table tests.

Testing damage conditions and dynamic characteristics, including frequency, acceleration coefficient, and displacement response, were investigated. After a comparison of those factors for each specimen, a comprehensive evaluation of seismic performance was conducted. The results showed better coordination between those structural measures and RE walls during the whole loading process. These structural measures are still useful in preventing specimen deformation, even in the case that RE walls were divided into pieces during subsequent loading operations. Additionally, each specimen's residual seismic capacity may still be able to withstand more intense earthquake excitations. It is simple to infer that such inner reinforcements are appropriate for RE buildings after considering the entire construction process at a site and the shaking table test results. Consequently, single-story inner-reinforced RE buildings may be built widely throughout China[18].

Another method was also presented by Wang in an article that presented a method for reinforcing existing rammed-earth buildings by strengthening the walls with externally bonded fibers. Shaking table tests were conducted to study the seismic performance of two rammed-earth model structures—with and without reinforcement. They observed the crack patterns, failure modes, changes in dynamic properties, in-plane deformation, wall response, and roof–wall interaction in the models. The results confirmed that the seismic resistance of rammed-earth structures reinforced using the proposed method was substantially improved [16]. An intriguing subject that requires in-depth research is the seismic performance of RE buildings. Two vertical steel rods positioned at the walls' extremities are used in another work to give a numerical analysis that evaluates the applicability of a seismic reinforcing technology for RE walls. RE walls that were reinforced and those that weren't were modeled using the discrete element method (DEM). In order to imitate vertical loads, these walls were first loaded with vertical tension on top, and then they were made to submit to horizontal loading on top to simulate seismic action. Two current cases of RE buildings were investigated: one-story and two-story buildings. The results showed that the reinforcement technique enhanced the maximum horizontal force by about 25% and 10%, respectively, for the cases of one- and two-story buildings. Higher effectiveness of this reinforcement technique is expected for RE materials having higher compressive strength, for example, stabilized RE[19]. In another study, it was stated that the researcher had strengthened these structures by using a new method, and these walls were pulled outward by an excavator with a cable. The reinforced sample showed a resistance of about 59% higher than the non-reinforced sample[20]. Many articles have been presented in this regard. However, as mentioned, many of these articles have many similarities. The presented methods are not practical in the construction industry without

considering economic and practical factors such as the duration of construction, beauty, and popularity among people. However, this research is very important in terms of seismic engineering, energy consumption analysis, and also in the field of sustainable development

## Method

In the conducted research, the modeled structure was analyzed in the Bam earthquake. Because this earthquake has been the most destructive in Iran in the last 50 years. In a city named Bam. Another important aspect of the investigation into this earthquake was the existence of many traditional houses that were built based on earthen materials. In a city where these types of structures were practically destroyed.

The structure designed in this model uses a new material in its construction, which was tested in the Sharif University of Technology laboratory and applied to the software. In the following text, the specifications of this material are provided.

According to the laws of physics, the center of mass is the point where all external forces are applied. As a result, it should be expected that with the weight of the foundation and placing the center of mass in its proper place, more force will be applied to the structure. If this method is correct, it is the first time that seismic improvement is done by increasing the weight of the structure. This modeling was analyzed with Abaqus 2021 software, and the calculation results were also compared with Iran's 2800 regulations.

### *Geometry of the structure*

The dimensions of the structure and foundation are shown in Figure 1. It can be seen that the thickness of the walls is 25 cm, and the thickness of the ceiling is 20 cm. Also, in order to investigate the effects of foundation depth on the seismic behavior of the designed structure, the foundation of this structure was designed in three different sizes according to Figure 2.

### *Arrangement of ceiling beams*

To increase the bending strength of the structure against the earthquake load, an arrangement of beech wooden beams is considered according to Figure 3. The cross-sectional dimensions of these beams are shown in Figure 4.

### *Materials Specifications*

The physical and mechanical properties of the material used in this structure were obtained from the pressure test. Also, type 3 soil was considered the base material for this structure. In addition, beech wood with a moisture content of 12% was also used as a component of the transverse beams of the roof. All physical and mechanical properties used in this article are stated in Table 1.

*Characteristics of the center of mass of the structure*

To improve the performance of the structure during an earthquake, the depth of the foundation was designed in such a way that the center of mass of the entire structure and foundation is located inside the foundation or around the center of the foundation. In Table 2, the total mass of the structure and the foundation for each of the plans in question are stated. In addition, the location of the center of mass of the structure in each of these designs is also shown in Figure 5. It can be seen that as the depth of the foundation increases, the center of mass of the structure moves down.

*Earthquake acceleration maps*

According to the data available in the database of the Seismography Network of Iran, the acceleration of Bam earthquake maps is as follows. Figure (6-8)

*Contacts and determination of substrate properties*

To maintain the integrity of different parts of the structure and foundation, the walls and roof were

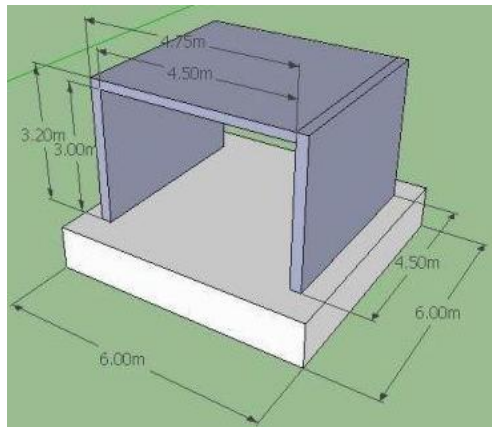

**Figure 1.** Structure and foundation dimensions.

integrated at the connection points due to seismic improvements. This action is also performed in the implementation of the structure. This makes the structure more resistant to earthquakes.

*Solver settings*

This study uses implicit transient dynamics as its analytical basis. For this purpose, the beginning time step was set at 0.25 seconds. Nevertheless, the program automatically lowered the solution's time step to around 0.005 seconds during the solution because of the seismic acceleration's abrupt shifts. A total of 20 seconds were thought to have passed throughout the analysis.

*Meshing*

At this stage, the geometry of the structure and the foundation were meshed using the organized grid according to figures 9 to 11. The dimensions of the grid were adjusted so that the mesh is acceptably smaller at the point of contact between the walls and the ceiling. Also, the meshing of the foundation in the adjacent areas of the structure was considered finer.

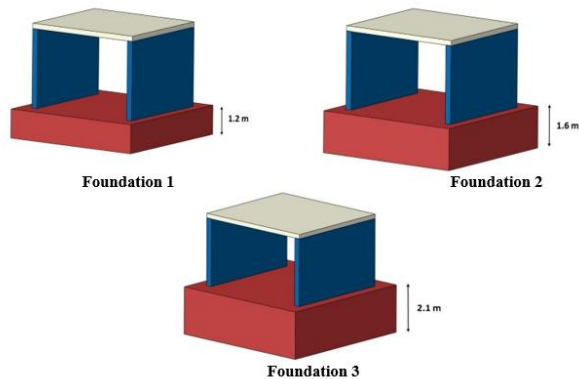

**Figure 2.** The foundation was designed for the structure at 3 different depths.



**Figure 3.** Arrangement of roof beams.

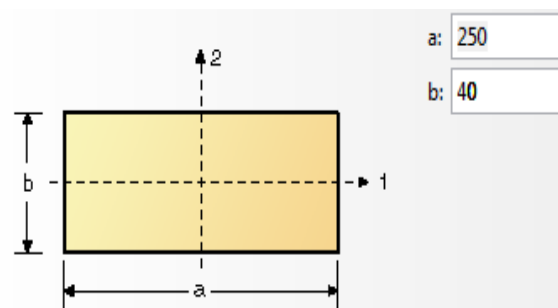

**Figure .** Cross-section dimensions of roof beams in millimeters.

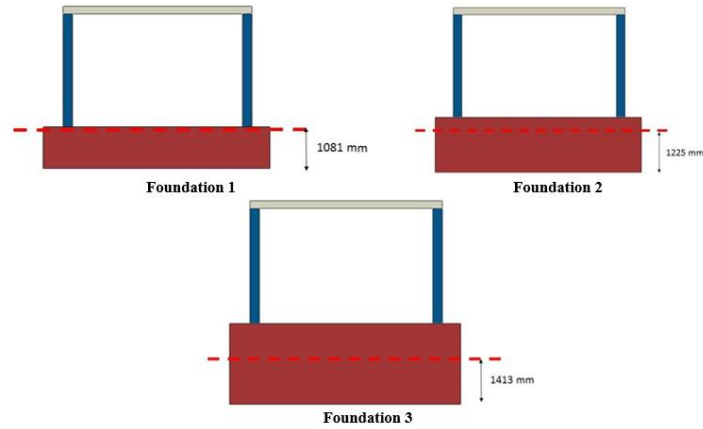

Figure 5. The foundation was designed for the structure at three different depths.

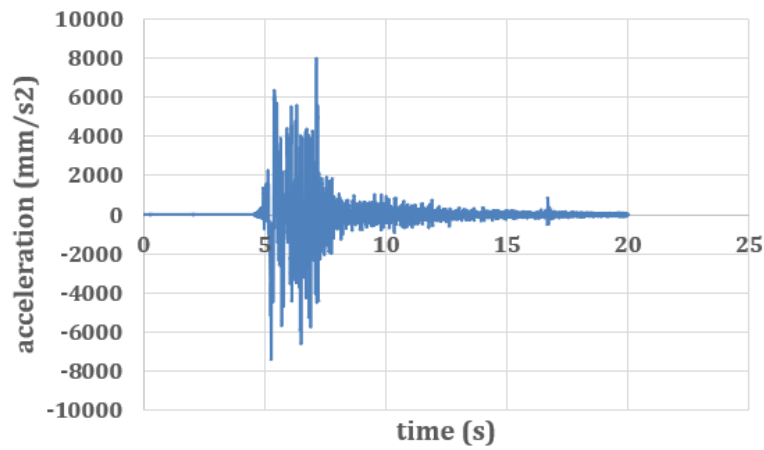

Figure 6. Acceleration of Bam earthquake along the X-axis.

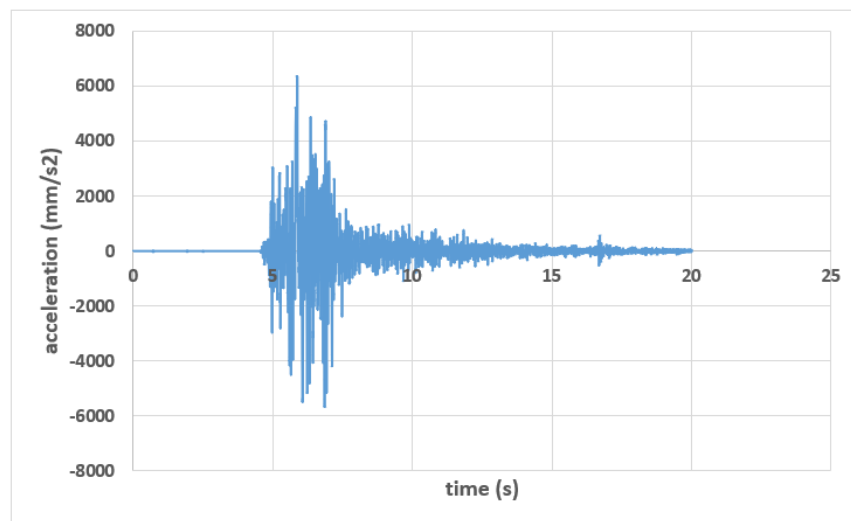

Figure 7. Bam earthquake acceleration along the Y-axis.

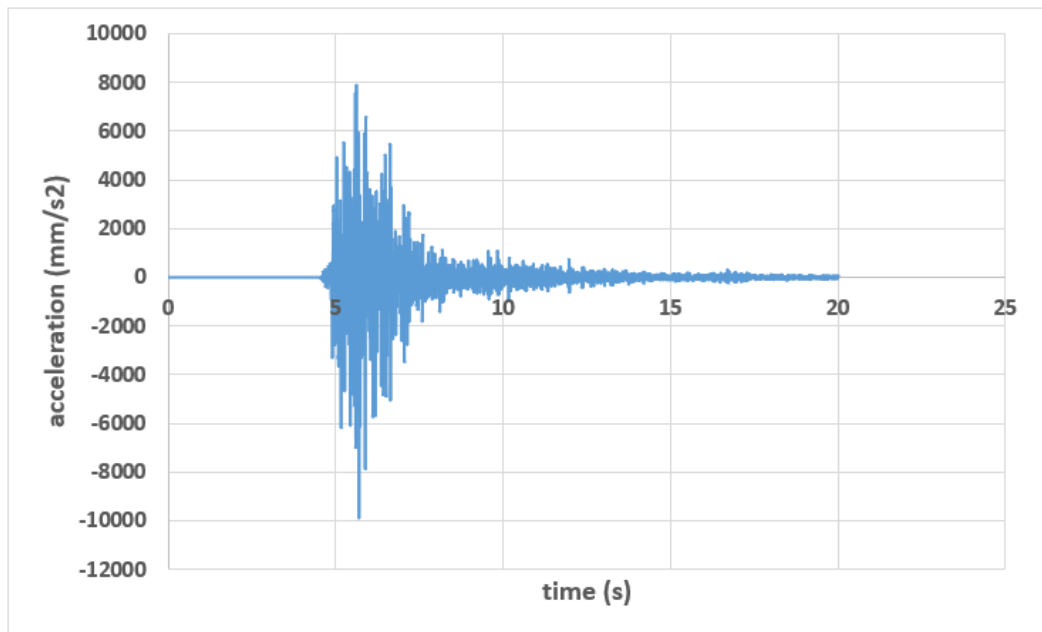

Figure 8. Bam earthquake acceleration along the Z-axis.

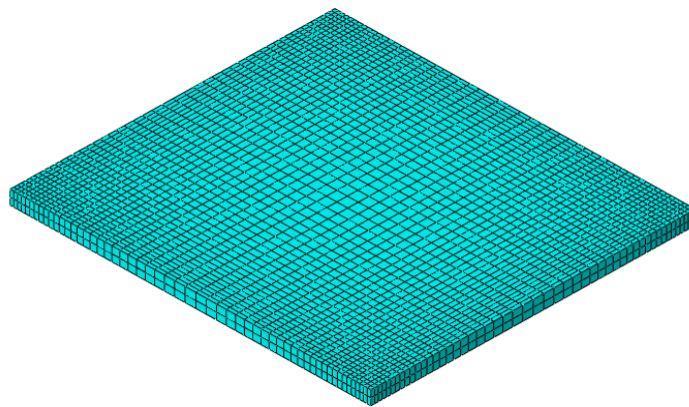

Figure 9. Roof meshing of the structure.

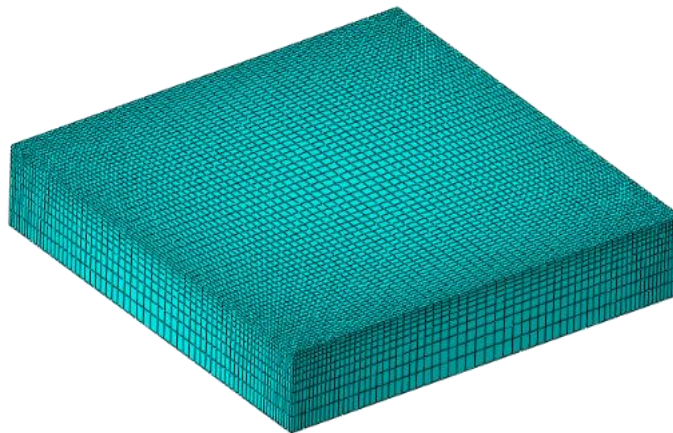
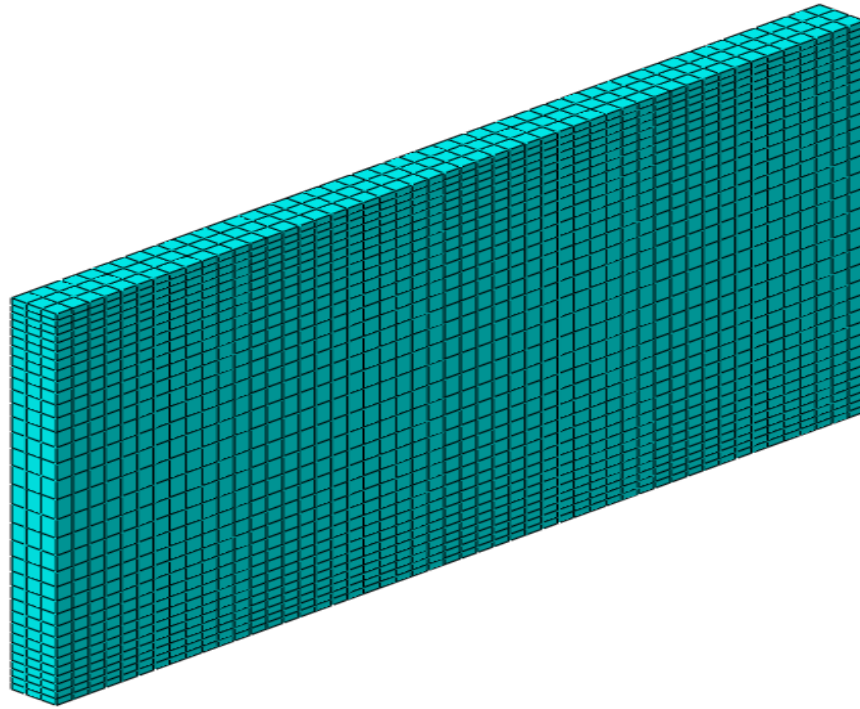

Figure 10. Foundation meshing of the structure.



**Figure 11.** The meshing of the walls of the structure.

**Table 1.** Physical and mechanical properties used in seismic analysis.

<b><u>Material used</u></b>	
1200	Density (Kg/m <sup>3</sup> )
2500	Elastic modulus (MPa)
6	Yield stress (MPa)
<b><u>Type III soil</u></b>	
1442	Density (Kg/m <sup>3</sup> )
20	Elastic modulus (MPa)
<b><u>Beechwood</u></b>	
800	Density (Kg/m <sup>3</sup> )
11900	Elastic modulus (MPa)

**Table 2.** Total mass of structure and foundation for different designs.

Design number	Mass (Tons)
1	71
2	97
3	123

**Results**

*Seismic analysis results based on foundation number one*

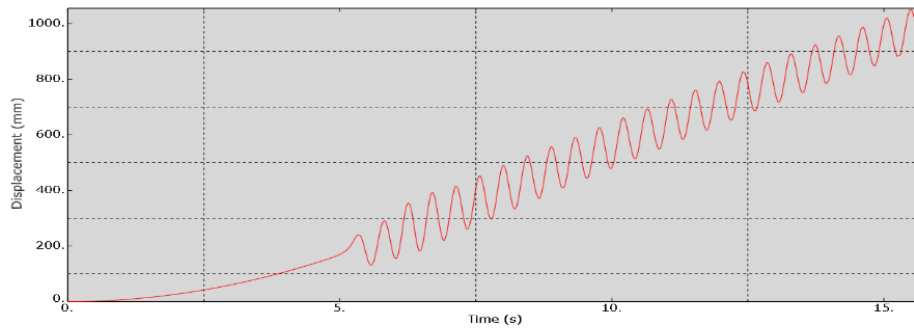

**Figure 12.** Movement of the roof center of the structure during the earthquake.

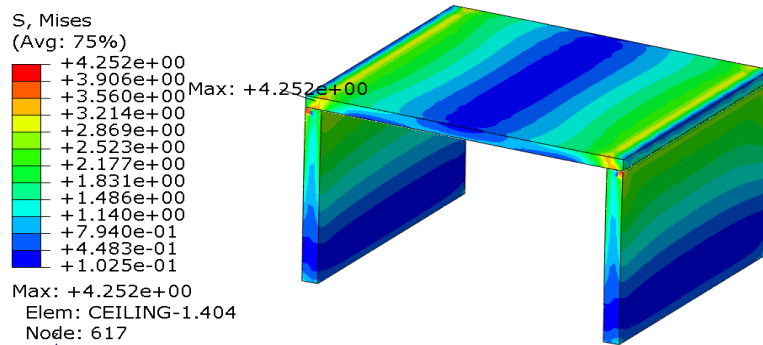

**Figure 13.** The maximum stress created during earthquake loading in megapascals.

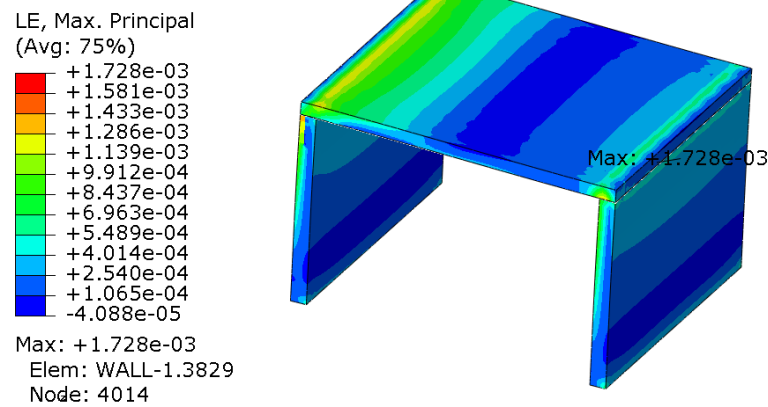

**Figure 14.** Maximum strain generated during earthquake loading.

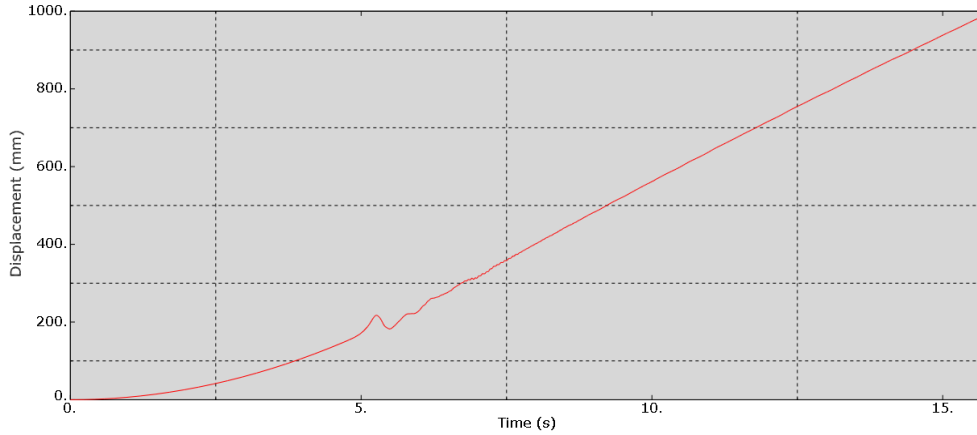

Figure 15. The average displacement of the structure land during the earthquake.

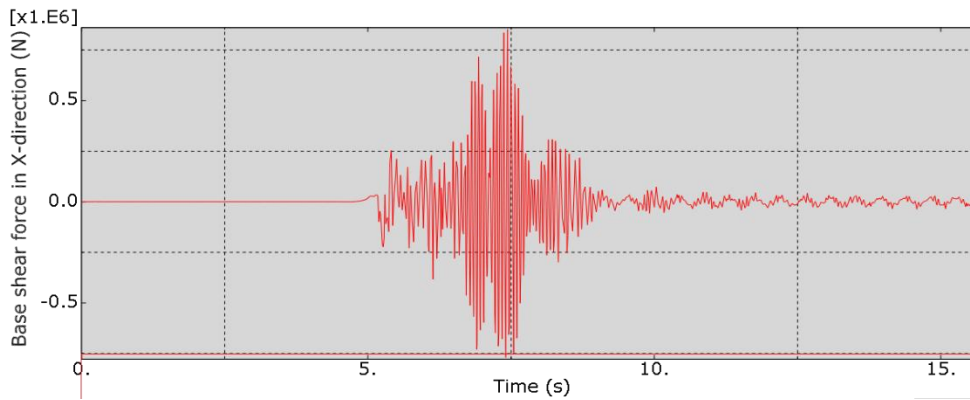

Figure 16. Base shear created in the structure in x-direction in terms of Newton.

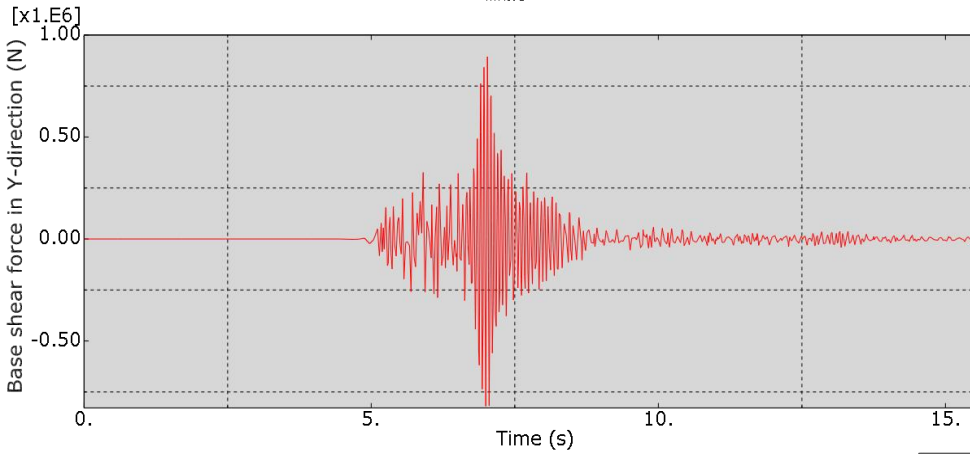

Figure 17. Base shear created in the structure along the y-direction in terms of Newton.

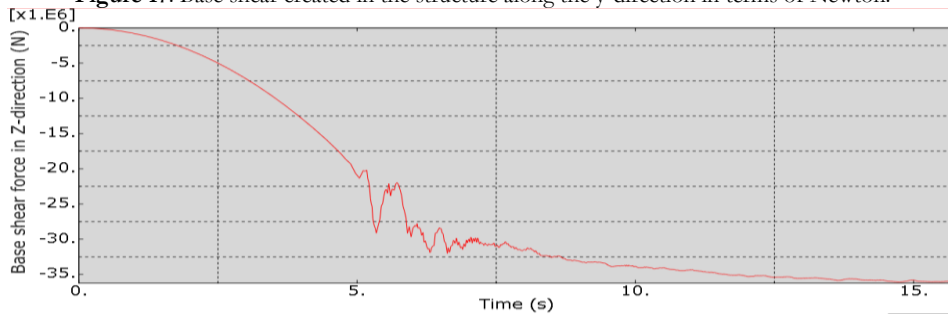

Figure 18. The force created in the structure in the z direction in terms of Newtons.

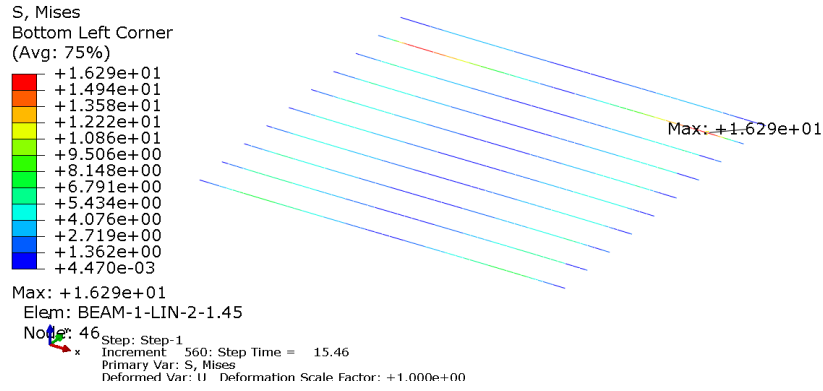

Figure 19. The maximum stress created in the transverse beams of the roof in megapascals.

Seismic analysis results based on foundation number two

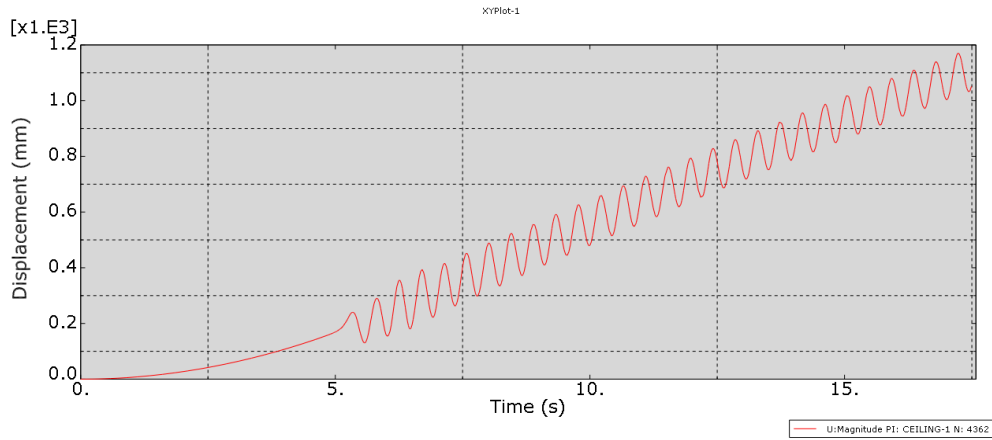

Figure 20. Movement of the roof center of the structure during the earthquake

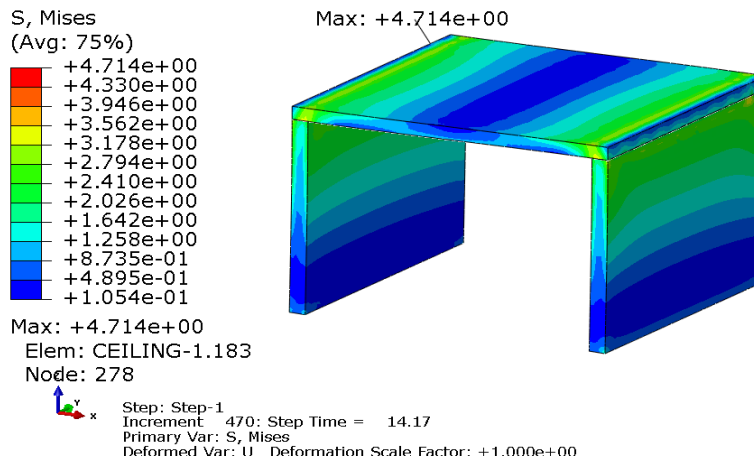

Figure 21. The maximum stress created during earthquake loading in megapascals.

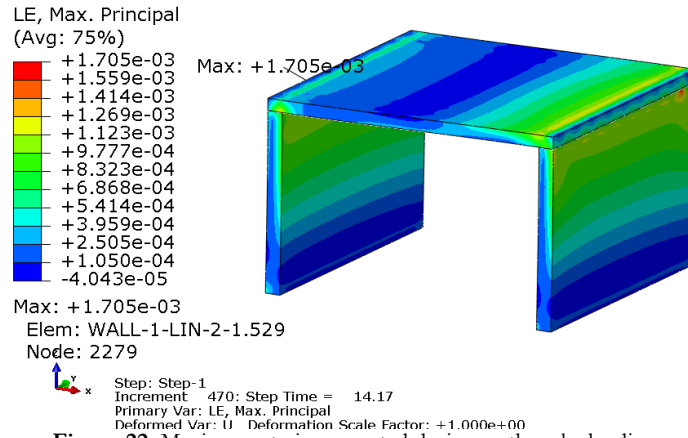

Figure 22. Maximum strain generated during earthquake loading.

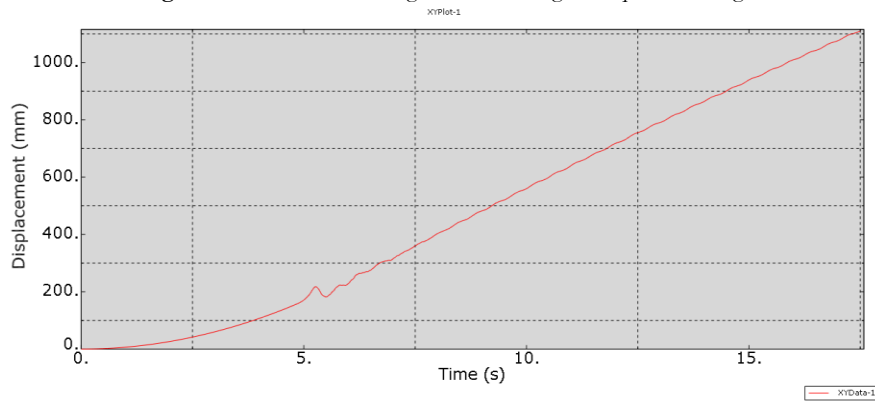

Figure 23. The average displacement of the structure land during the earthquake

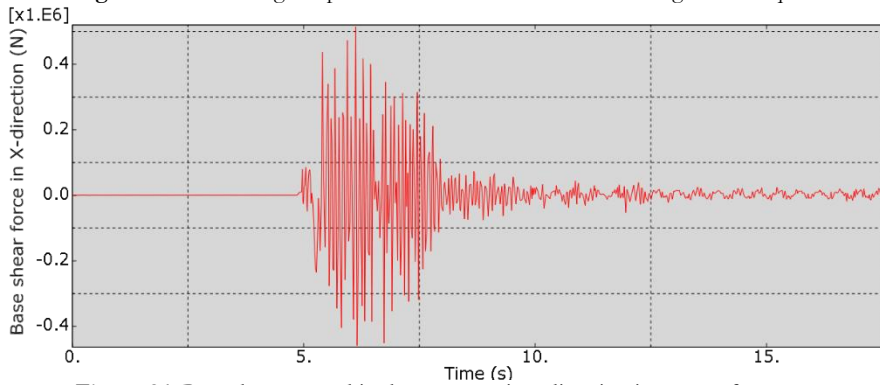

Figure 24. Base shear created in the structure in x direction in terms of Newton.

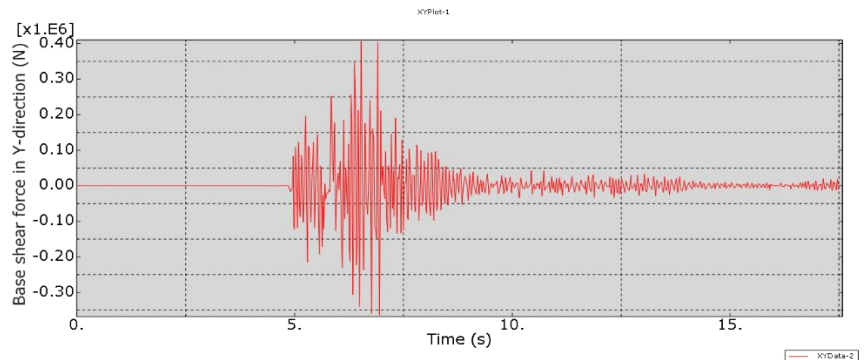

Figure 25. Base shear created in the structure along the y direction in terms of Newton.

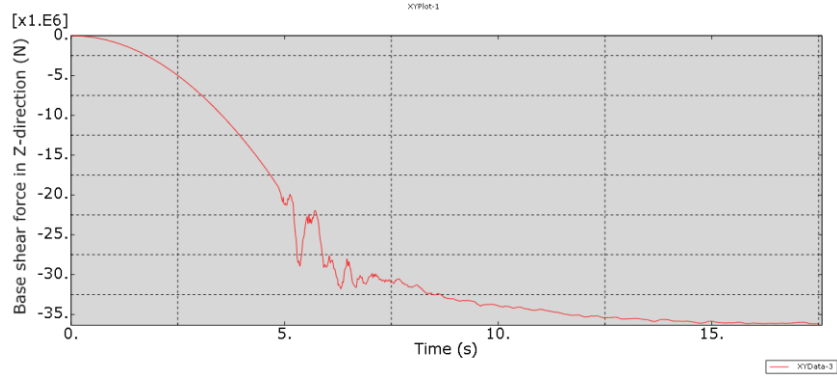

Figure 26. The force created in the structure in the z direction in terms of newtons.

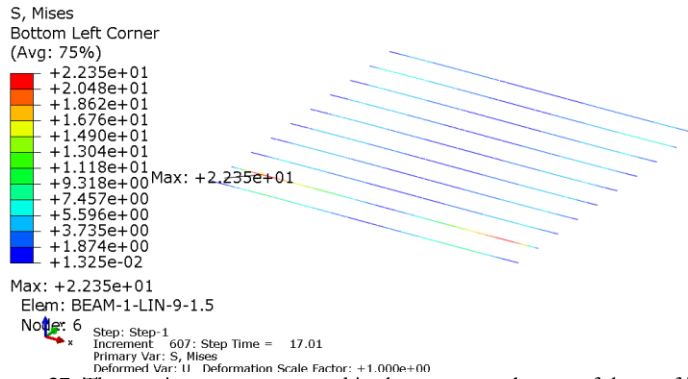

Figure 27. The maximum stress created in the transverse beams of the roof in megapascals.

Seismic analysis results based on foundation number three

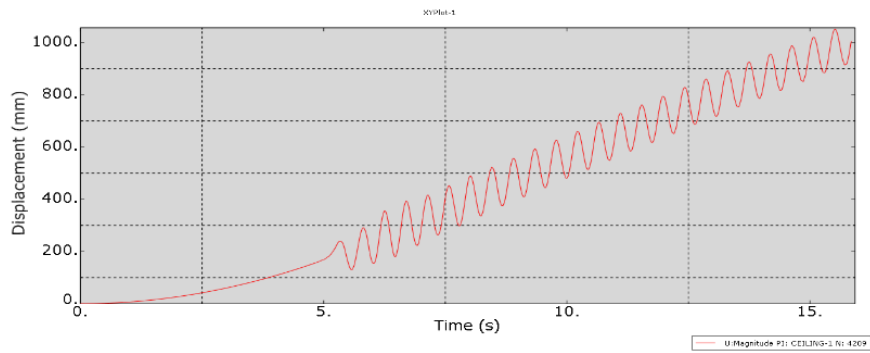

Figure 28. Movement of the roof center of the structure during the earthquake.

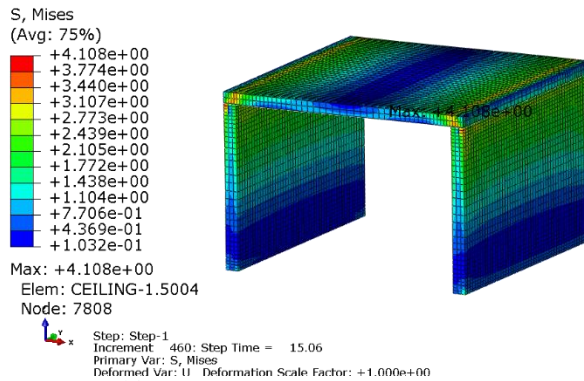

Figure 29. The maximum stress created during earthquake loading in megapascals.

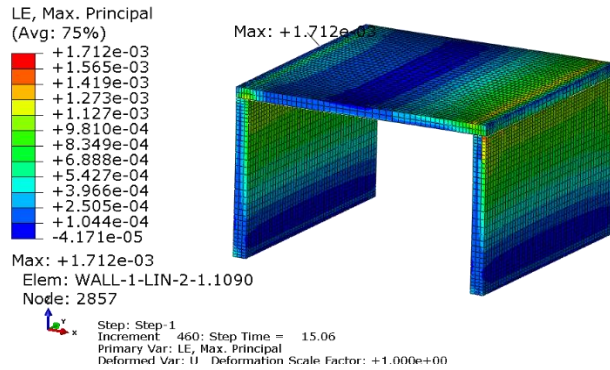

Figure 30. Maximum strain generated during earthquake loading.

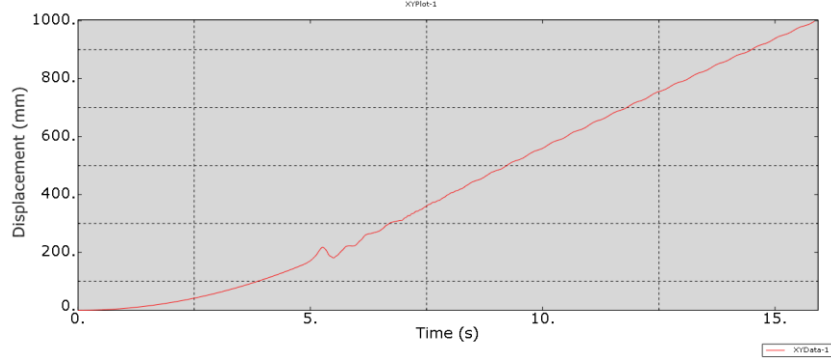

Figure 31. Average ground displacement of the structure during the earthquake.

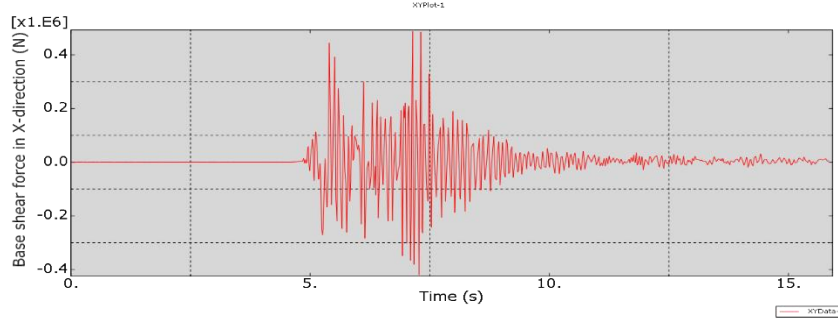

Figure 32. Base shear created in the structure in x direction in terms of Newton.

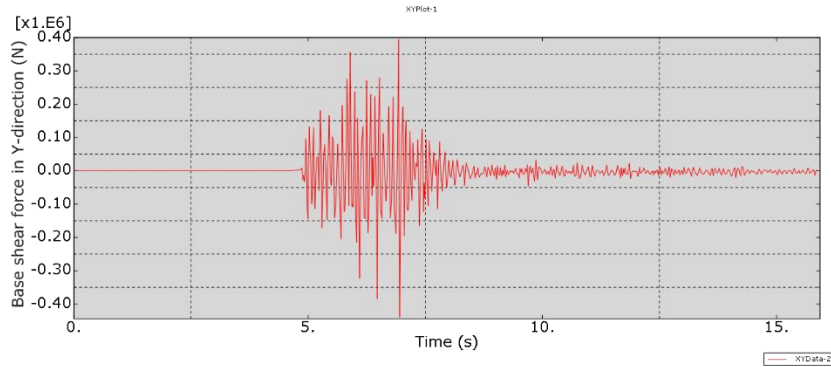

Figure 33. Base shear created in the structure along the y direction in terms of Newton.

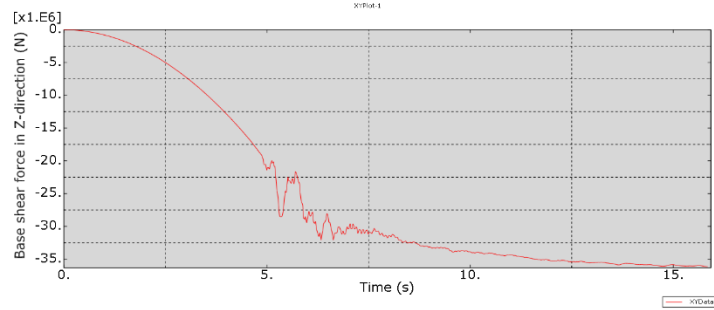

Figure 34. The force created in the structure in the z direction in terms of Newton.

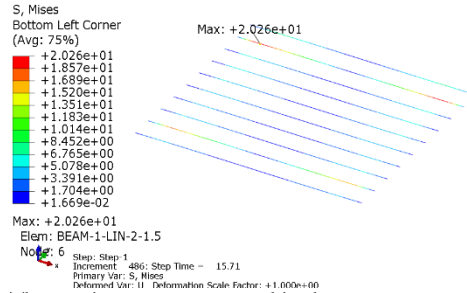

Figure 35. The maximum stress created in the transverse roof beams in megapascals.

*Calculation of base shear in the structure based on Iran's 2800 regulations*

Based on this regulation, the parameters used are shown in Table 3.

Table 3. Parameters used in regulation 2800.

The name of the quantity	Explanation of quantity	Amount
A	Design basis acceleration for the zone with high seismicity	0.35
B	The reflection coefficient of the building for the third type of land	6.545
T	The first period of the structure (calculated by Abaqus)	0.5 second
I	The coefficient of importance of the structure	1
R <sub>u</sub>	Building behavior factor of reinforced masonry materials	3
W <sub>d</sub>	Percentage of live load	20% of dead weight

Table 4. The result of the evaluation of base shear caused by earthquake based on the 2800 regulations.

	Dead load weight (W) in kilonewtons	Base shearing limit ( $V_u = \frac{ABI}{R_u} (W + W_d)$ ) in kilonewtons	Maximum actual base shear in kilonewtons	Result
Foundation 1	710	650	800	need correction
Foundation 2	970	888	500	OK
Foundation 3	1230	1127	400	OK

**Discussion**

A very positive point in this research is the very low cost of these structures considering the materials used in them. If the parts of these structures are industrially

produced in prefabricated form and installed and implemented on-site. For a 100-meter plot and 2 floors, the cost is 10 dollars per meter of construction until the stage of the framework, and the cost of finishing can be different according to the employer's choice.

Also, in the case of prefab and industrial construction, according to estimates, the duration of construction of this 2-story building until the framework stage is 1-2 days.

These differences cause these types of structures to have problems such as:

- Design weakness
- Construction time
- Lack of industrial implementation
- Construction cost
- Seismic improvement
- Energy efficiency
- Acoustic engineering
- Complying with sustainable development rules, especially the LEED reference
- Build different numbers of floors

All of them make this type of structure have a great position in competition with other construction methods.

According to surveys, the cost of the cheapest structure in the world is Pole Barn House, which will cost 121.5 dollars per meter. Apart from the disadvantages and limitations that these types of structures will have, this shows that the presented method is the cheapest structure that can be built in the lowest possible state. [21]

## Conclusion

It may be concluded that this structure is capable of resisting an earthquake of the same magnitude as the Bam earthquake by completing the finite element study mentioned above and comparing it with the 2800 regulations based on the following clauses:

1. The stress level in the roof and walls is completely lower than the strength of the material used.
2. The level of stress in wooden beams is as much as it can be tolerated by them.
3. Wooden beams provide a major part of the bending strength of the structure.
4. Due to the existence of wooden beams, the distribution of stress in the roof changes in such a way that the possible failure of the roof in more severe earthquakes will not be avoided. Rather, one side will collapse. Therefore, it is necessary to use reinforcement on the sides of the roof.
5. By increasing the depth of the foundation, the center of mass of the structure is moved lower, and as a result, the safety margin of the structure against the shear force and bending moment caused by the earthquake load increases.
6. The uniformity of the structure during the construction process is a basic condition for the above statements to be valid. Considering that the acceleration of the earthquake based on the plan based on the 2800 regulation is about one-third of the acceleration of the

earth's gravity and considering that the maximum acceleration of the Bam earthquake is equal to the acceleration of the earth's gravity, therefore, it can be said that this structure could withstand an earthquake up to the magnitude of the Bam earthquake or earthquakes with intensity IX. Violent will have the Mercalli scale.

Also, due to the use of special and affordable materials, these types of structures can cost up to 10 dollars per meter in industrial dimensions. **The economic efficiency of this method will be investigated in a separate study.**

## Patents

A patent with the number [WO2021038272A2](#) has been registered under the conducted research.

## References

1. T. D. Nguyen, T. T. Bui, A. Limam, T. L. Bui, and Q. B. Bui, 'Evaluation of seismic performance of rammed earth building and improvement solutions', *Journal of Building Engineering*, vol. 43, Nov. 2021, doi: 10.1016/j.jobe.2021.103113.
2. G. M. Calvi, 'A displacement-based approach for vulnerability evaluation of classes of buildings', *Journal of earthquake Engineering*, vol. 3, no. 03, pp. 411–438, 1999.
3. R. El Nabouch, Q.-B. Bui, O. Plé, and P. Perrotin, 'Rammed earth under horizontal loadings: Proposition of limit states', *Constr Build Mater*, vol. 220, pp. 238–244, 2019.
4. Q.-B. Bui, T.-T. Bui, M.-P. Tran, T.-L. Bui, and H.-A. Le, 'Assessing the seismic behavior of rammed earth walls with an L-form cross-section', *Sustainability*, vol. 11, no. 5, p. 1296, 2019.
5. T.-L. Bui, T.-T. Bui, Q.-B. Bui, X.-H. Nguyen, and A. Limam, 'Out-of-plane behavior of rammed earth walls under seismic loading: Finite element simulation', in *Structures*, Elsevier, 2020, pp. 191–208.
6. D. Easton, *The rammed earth house*. Chelsea Green Publishing, 2007.
7. Q.-B. Bui, T.-T. Bui, R. El-Nabouch, and D.-K. Thai, 'Vertical rods as a seismic reinforcement technique for rammed earth walls: an assessment', *Advances in Civil Engineering*, vol. 2019, 2019.
8. L. Miccoli, U. Müller, and S. Pospíšil, 'Rammed earth walls strengthened with polyester fabric strips: Experimental analysis under in-plane cyclic loading', *Constr Build Mater*, vol. 149, pp. 29–36, 2017.
9. F. Ávila, E. Puertas, and R. Gallego, 'Characterization of the mechanical and physical properties of stabilized rammed earth: A review', *Construction and Building Materials*, vol. 325. Elsevier Ltd, Mar. 28, 2022. doi: 10.1016/j.conbuildmat.2022.126693.
10. A. Koutous and E. Hilali, 'Reinforcing rammed earth with plant fibers: A case study', *Case Studies in Construction Materials*, vol. 14, p. e00514, 2021.

11. V. Toufigh and E. Kianfar, 'The effects of stabilizers on the thermal and the mechanical properties of rammed earth at various humidities and their environmental impacts', *Constr Build Mater*, vol. 200, pp. 616–629, 2019.
12. P. Zare, S. S. Narani, M. Abbaspour, A. Fahimifar, S. M. M. M. Hosseini, and P. Zare, 'Experimental investigation of non-stabilized and cement-stabilized rammed earth reinforcement by Waste Tire Textile Fibers (WTTFs)', *Constr Build Mater*, vol. 260, p. 120432, 2020.
13. M. M. Hallal, S. Sadek, and S. S. Najjar, 'Evaluation of engineering characteristics of stabilized rammed-earth material sourced from natural fines-rich soil', *Journal of Materials in Civil Engineering*, vol. 30, no. 11, p. 04018273, 2018.
14. V. Strazzeri, A. Karrech, and M. Elchalakani, 'Micromechanics modelling of cement stabilised rammed earth', *Mechanics of Materials*, vol. 148, p. 103540, 2020.
15. D. Ciancio, C. T. S. Beckett, and J. A. H. Carraro, 'Optimum lime content identification for lime-stabilised rammed earth', *Constr Build Mater*, vol. 53, pp. 59–65, 2014.
16. Y. Wang, M. Wang, K. Liu, W. Pan, and X. Yang, 'Shaking table tests on seismic retrofitting of rammed-earth structures', *Bulletin of Earthquake Engineering*, vol. 15, no. 3, pp. 1037–1055, Mar. 2017, doi: 10.1007/s10518-016-9996-2.
17. T. Zhou, Z. Zhang, Z. Su, and P. Tian, 'Seismic performance test of rammed earth wall with different structural columns', *Advances in Structural Engineering*, vol. 24, no. 1, pp. 107–118, Jan. 2021, doi: 10.1177/1369433220944506.
18. T. Zhou and B. Liu, 'Experimental study on the shaking table tests of a modern inner-reinforced rammed earth structure', *Constr Build Mater*, vol. 203, pp. 567–578, Apr. 2019, doi: 10.1016/j.conbuildmat.2019.01.070.
19. Q. B. Bui, T. T. Bui, R. El-Nabouch, and D. K. Thai, 'Vertical Rods as a Seismic Reinforcement Technique for Rammed Earth Walls: An Assessment', *Advances in Civil Engineering*, vol. 2019, 2019, doi: 10.1155/2019/1285937.
20. K. C. Shrestha *et al.*, 'Strengthening of rammed earth structures with simple interventions', *Journal of Building Engineering*, vol. 29, May 2020, doi: 10.1016/j.jobbe.2020.101179.
21. T. Hazen, 'What Is the Cheapest Type of House to Build? (2024)'. Accessed: Feb. 25, 2024. Online]. Available: <https://homeguide.com/costs/cheapest-type-of-house-to-build>.

## SJIS

**Copyright:** © 2025 The Author(s); This is an open-access article distributed under the terms of the Creative Commons Attribution License (<http://creativecommons.org/licenses/by/4.0>), which permits unrestricted use, distribution, and reproduction in any medium, provided the original work is properly cited.

**Citation:** Hashemian MH, Vahdati M. Seismic simulation of seismically improved RE (rammed earth) buildings. *SJIS*, 2025; 7(2): 1-16.

<https://doi.org/10.47176/sjis.7.2.1>